



Model ECXP40-Y

8" - 14 gauge spun aluminum ball
gold anodized

Single sheave truck, cast aluminum
revolving, non-fouling type

2 Bronze swivel snaps with covers
per halyard

3 Sets of halyard: #10 poly

11' Yardarm

3 - 9" Cast aluminum cleat

Aluminum flash collar

3000 PSI concrete

Hardwood wedges
(supplied by others)

Dry sand tightly tamped
after aligning pole

Foundation sleeve -16 ga
hot dip galvanized steel

Steel centering wedges

1/4" Steel base plate

1/4" Steel support plate
welded to grounding spike

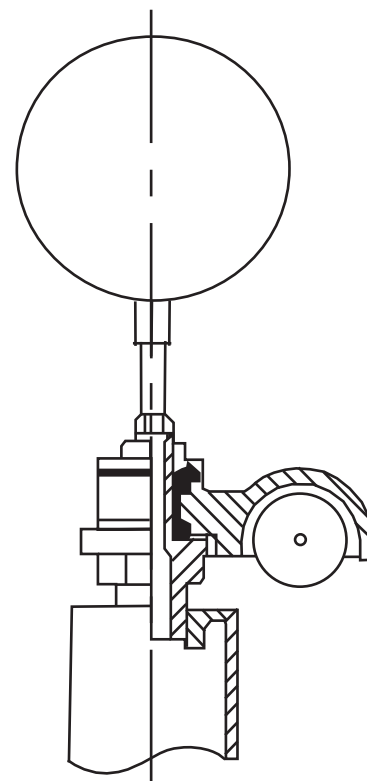
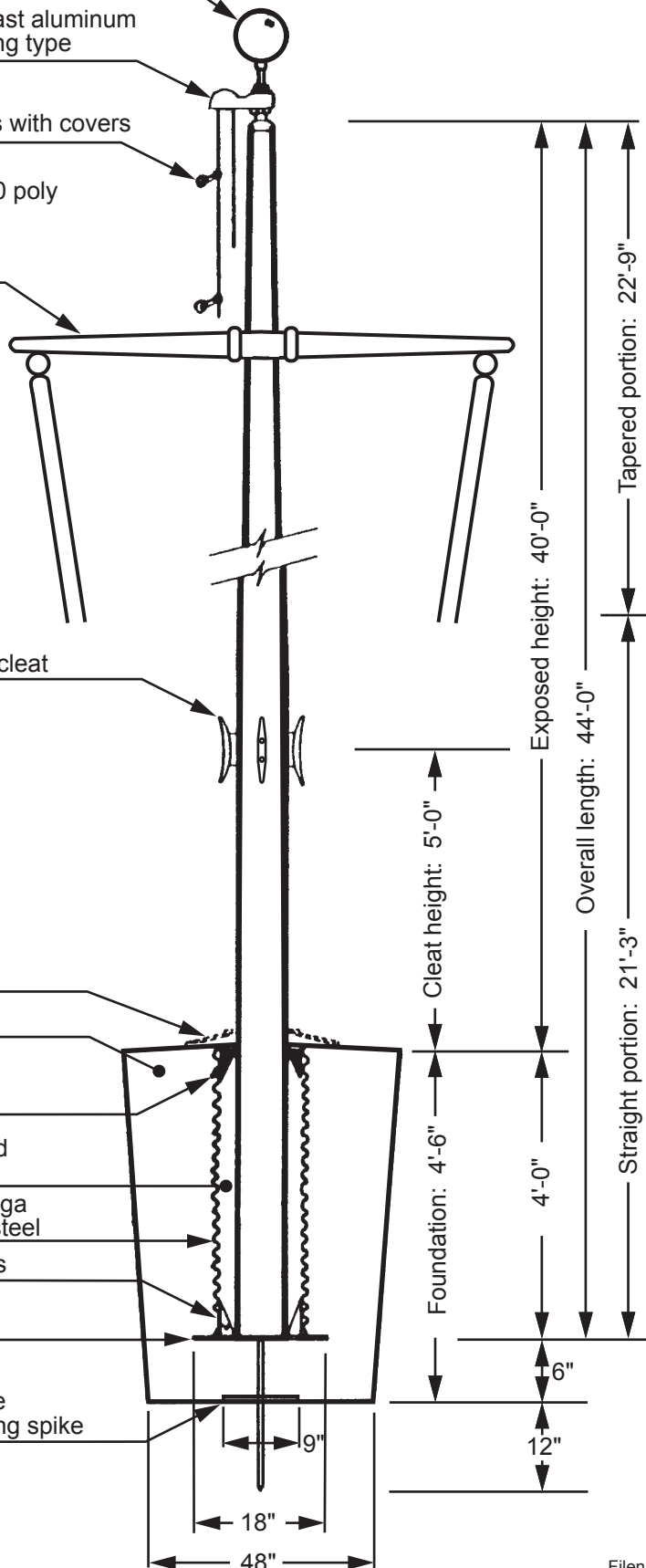

Truck Detail

Aluminum body
Stainless steel ball bearings
Aluminum sheave
Cast aluminum spindle

All shafts with overall
length of more than
38'-6" are shipped in
two sections.

Each section matched
marked for field assembly.
Exposed portion of jam
sleeve must be **well
lubricated** prior to
assembly.

1-1/2" maximum shop
gap allowed for field
fitting (ram for tight joint)

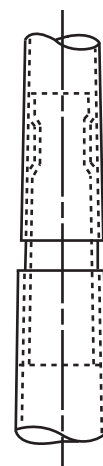

Filename: ECXP40-Y single sheave_revolving truck.ai

Project:	Ground set tapered aluminum flagpole: ALLOY: 6063T6	EDER FLAG	Date:
Location:	Exposed height: 40'-0"	Overall height: 44'-0"	Revision:
Architect:	Ship in 1 section	Butt diameter: 7"	1000 W. Rawson Avenue
Contractor:	Top diameter: 3-1/2"	Wall thickness: .156"	Oak Creek, WI 53154
Customer:	Finish: 100 grit polish		Job: