

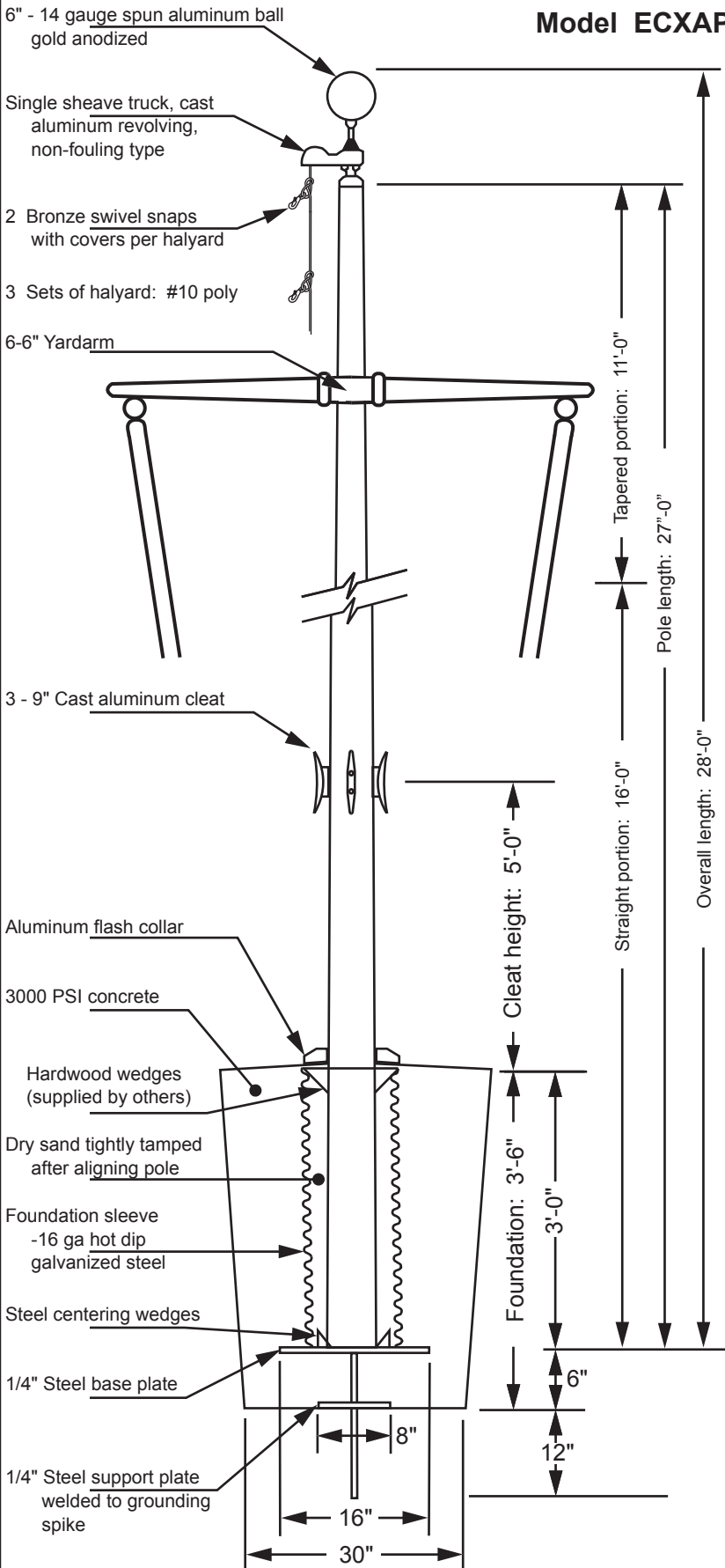

# Model ECXAP25 -Y

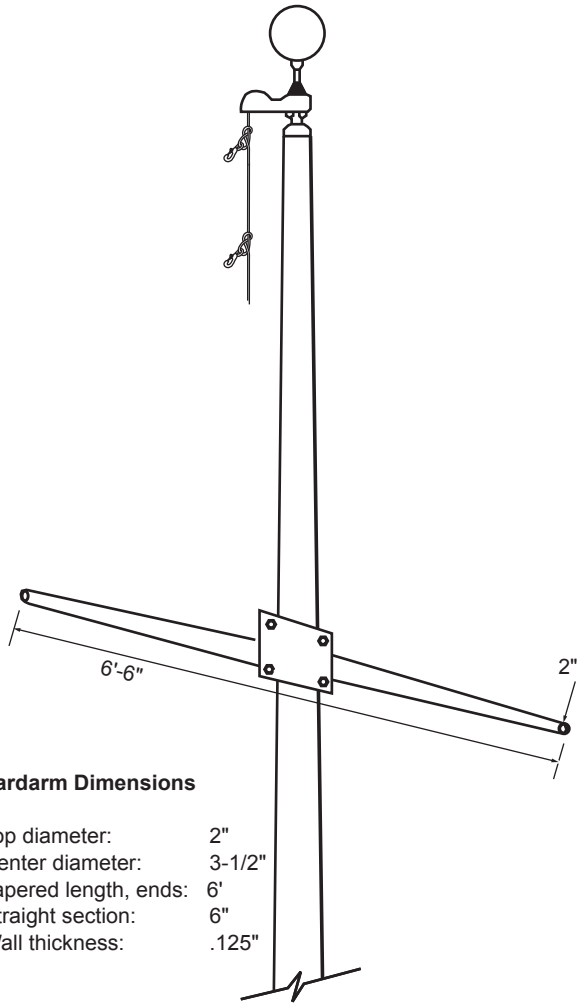

- 6" - 14 gauge spun aluminum ball gold anodized
- Single sheave truck, cast aluminum revolving, non-fouling type
- 2 Bronze swivel snaps with covers per halyard
- 3 Sets of halyard: #10 poly
- 6-6" Yardarm
- 3 - 9" Cast aluminum cleat
- Aluminum flash collar
- 3000 PSI concrete
- Hardwood wedges (supplied by others)
- Dry sand tightly tamped after aligning pole
- Foundation sleeve -16 ga hot dip galvanized steel
- Steel centering wedges
- 1/4" Steel base plate
- 1/4" Steel support plate welded to grounding spike



### Yardarm Dimensions

- Top diameter: 2"
- Center diameter: 3-1/2"
- Tapered length, ends: 6'
- Straight section: 6"
- Wall thickness: .125"

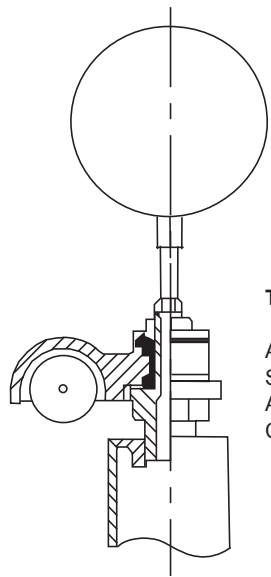

### Truck Detail

- Aluminum body
- Stainless steel ball bearings
- Aluminum sheave
- Cast aluminum spindle

Project:	Ground set tapered aluminum flagpole: ALLOY: 6063T6	EDER FLAG	Date:
Location:	Exposed height: 25'-0"	Overall height: 28'-0"	MANUFACTURING COMPANY
Architect:	Ship in 1 section	Butt diameter: 5"	1000 W. Rawson Avenue
Contractor:	Top diameter: 3"	Wall thickness: .156"	Oak Creek, WI 53154
Customer:	Finish: 100 grit polish		Job: