

### Model ECAP 40-Y

8" - 14 gauge spun aluminum ball  
gold anodized

Single sheave truck, cast aluminum  
revolving, non-fouling type

2 Bronze swivel snaps with covers  
per halyard

3 Sets of halyard: #10 poly

11' Yardarm

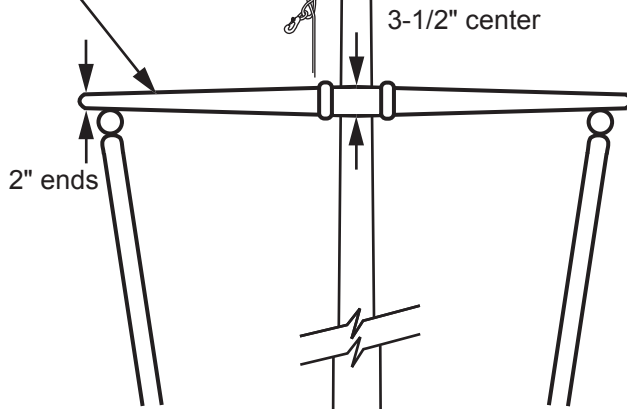

Exposed height: 40'-0"  
Tapered portion: 29'-1"

3 - 9" Cast aluminum cleat

Cleat height: 5'-0"  
Overall length: 44'-0"  
Straight portion: 19'-11"

Aluminum flash collar

3000 PSI concrete

Hardwood wedges  
(supplied by others)

Dry sand tightly tamped  
after aligning pole

Foundation sleeve -16 ga  
hot dip galvanized steel

Steel centering wedges

1/4" Steel base plate

1/4" Steel support plate  
welded to grounding spike

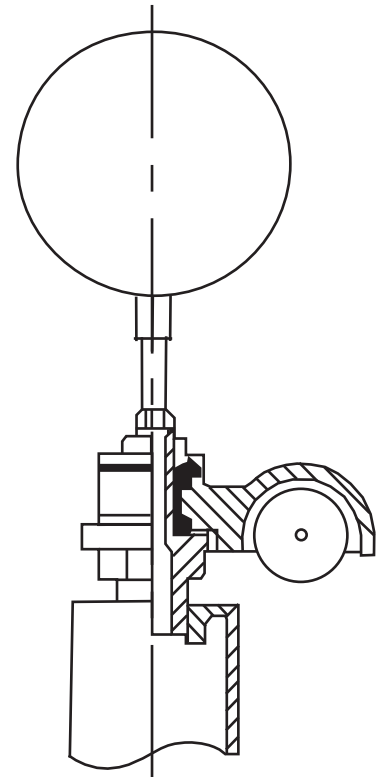
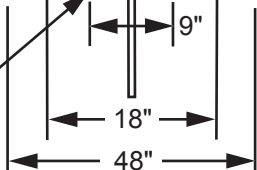

**Truck Detail**

Aluminum body  
Stainless steel ball bearings  
Aluminum sheave  
Cast aluminum spindle

All shafts with overall  
length of more than  
38'-6" are shipped in  
two sections.

Each section matched  
marked for field assembly.  
Exposed portion of jam  
sleeve must be **well  
lubricated** prior to  
assembly.

1-1/2" maximum shop  
gap allowed for field  
fitting (ram for tight joint)

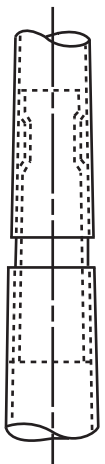

Project:	Ground set tapered aluminum flagpole: ALLOY: 6063T6	EDER FLAG	Date:
Location:	Exposed height: 40'-0"	Overall height: 44'-0"	MANUFACTURING COMPANY
Architect:	Ship in 2 sections	Butt diameter: 8"	1000 W. Rawson Avenue
Contractor:	Top diameter: 3-1/2"	Wall thickness: .156"	Oak Creek, WI 53154
Customer:	Finish: 100 grit polish		Job: